

(No Model.)

B. F. MEYER.
MECHANICAL MOVEMENT.

No. 330,255.

Patented Nov. 10, 1885.

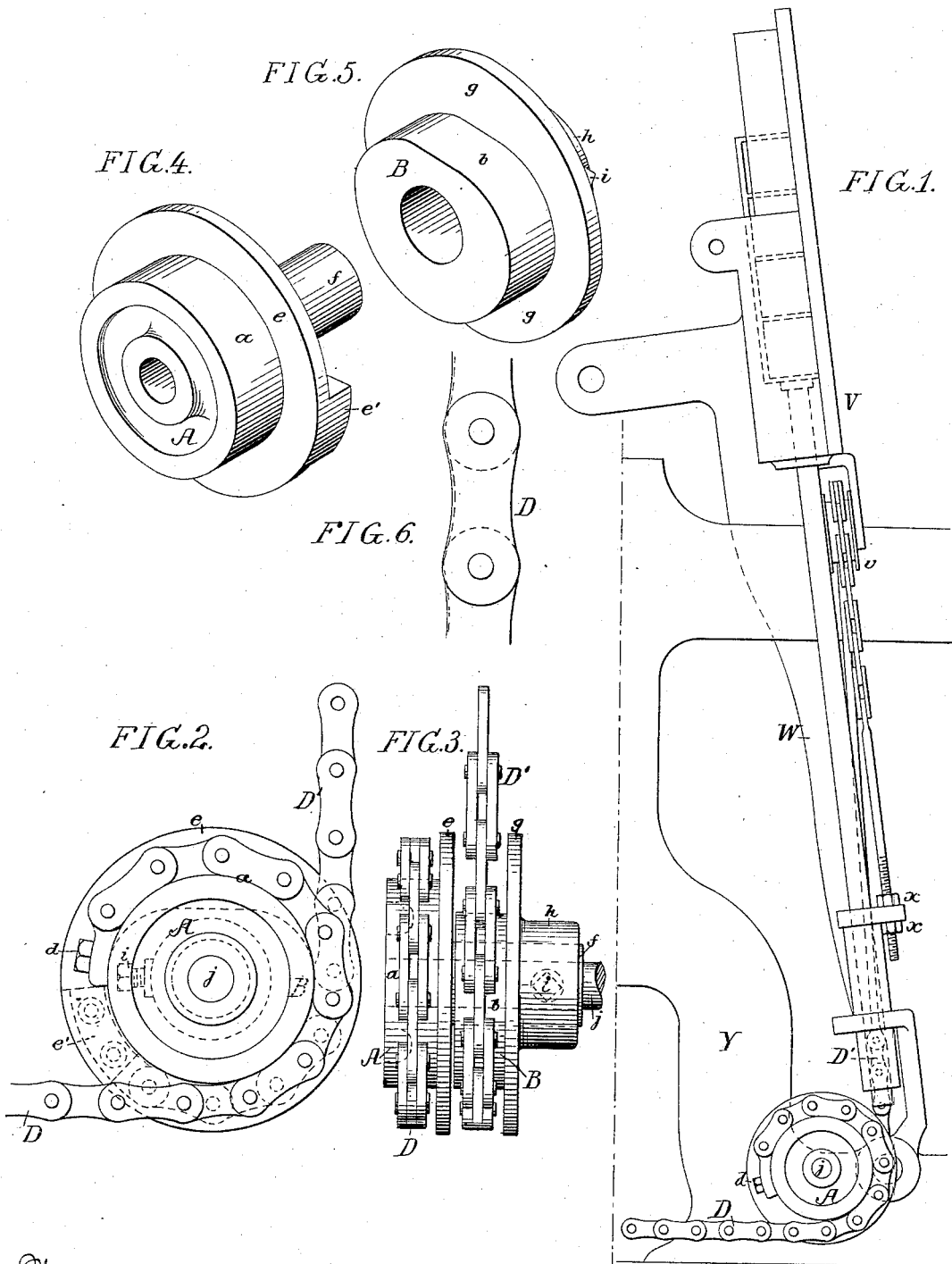

Witnesses:
John E. Parter
Harry Drury

Inventor:
Benj. F. Meyer
by his Attorneys
Howson & Sons

UNITED STATES PATENT OFFICE.

BENJAMIN F. MEYER, OF CAMDEN, N. J., ASSIGNOR TO MERRILL A. FURBUSH AND CHARLES A. FURBUSH, OF PHILADELPHIA, PA.

MECHANICAL MOVEMENT.

SPECIFICATION forming part of Letters Patent No. 330,255, dated November 10, 1885.

Application filed June 19, 1885. Serial No. 169,156. (No model.)

To all whom it may concern:

Be it known that I, BENJAMIN F. MEYER, a citizen of the United States, and a resident of Camden, New Jersey, have invented certain Mechanical Movements, of which the following is a specification.

The object of my invention is to construct a mechanical movement or device for compensating for the wear of driving or lifting chains.

In the accompanying drawings, Figure 1 is a view of my improvement as applied to the drop-box mechanism of a loom. Fig. 2 is a face view of the device. Fig. 3 is a side view. Figs. 4 and 5 are detached perspective views, and Fig. 6 is an enlarged view of part of the chain used.

Referring to Figs. 2 and 3, A is a sheave, to which is secured one end of a chain, D, by a bolt, *d*. This sheave has a flange, *e*, and a hub, *f*, and has its periphery turned to a true circle. On this hub is mounted a cam, B, Fig. 5, so as to be adjustable thereon, and this cam B also has a flange, *g*, and a hub, *h*. The cam B and sheave A are fastened together by a set-screw, *i*, and they are hung to a suitable stud, *j*. A chain, D', which is attached by bolts or otherwise to a lug, *e'*, on the flange *e* of the sheave A, passes over the face *b* of the cam B, as shown in Fig. 2.

As will be observed on reference to Figs. 1 and 6, where there is a constant working of a small portion of a chain over a sheave at the same portion thereof, both the chain and the sheave over which it passes wear away to a great extent. For instance, if two links wear away, as indicated by the dotted lines in Fig. 6, the center of that portion of the chain will be brought nearer to the center of the sheave than that of the unworn portion, and consequently the movement of the chain will be irregular; but by adjusting the cam B around on the hub of the sheave so as to throw the part of the chain not worn nearer the center and to correspond with the worn part, or to throw the worn part outward to correspond with the unworn part, the wear will then be properly compensated for and the movement of the chain be made regular.

In Fig. 1 I have shown my improvement as applied to a loom, the chain D' being connected to the lathe W of the loom and passing over a sheave, *v*, secured to the drop-box frame V, and being provided with adjusting-nuts *x*. The sheave A and cam B are adapted to a stud, *j*, projecting from the frame of the loom Y. In a loom of this construction, where the drop-boxes are lifted by chains, the loom may be run for months on two boxes, and then a new pattern may be used and four boxes come into use. It will then be found that the adjustment made to take up the wear on the chain for the two boxes by moving the adjusting-nuts *x* will not compensate for the variations caused by the wear of parts of the chain and sheave, but only for the slack caused by the lengthening of the chain incident to the wearing away of the pins, consequently the third or fourth box would be lifted too high if the first and second rise to the proper height, for if, say, two links wear away to the dotted lines, Fig. 6, it will bring the center line of the portion of the chain nearer the center of the sheave than that of the portion which comes into use when the remaining boxes are lifted.

By adjusting the cam B in the manner above described, however, the wear may be properly compensated for and all the boxes lifted to their proper heights.

This compensating device can be used in any chain-operated machine where the chain moves a greater or less extent at different times.

I claim as my invention—

The compensating device consisting of a sheave and a cam and chains passing over the same, the said cam being adjustable with reference to the sheave, as and for the purpose set forth.

In testimony whereof I have signed my name to this specification in the presence of two subscribing witnesses.

BENJAMIN F. MEYER.

Witnesses:

WILLIAM F. DAVIS,
HARRY SMITH.